

B1.1	B2.3	B1.1	B2.3	B1.1	B2.5	B1.2	B2.5	B1.2	B2.5	B1.2	B2.4	B1.2	B2.3	B1.2	B2.5	B1.1	B2.2	B1	B2.3	B1	B2.5	B1.3	B2.5	B1.3	B2.6	B1.3	B2.5	B1.3	B2.5	B1.4	
LH*-1595 HR-3215 1620	LH-1595 1620	LH-1975 HR-3975 1999	LH-1975 1999	LH-1975 HR-3975 1999	LH-1975 HR-3975 2000	LH-1975 HR-3975 2000	LH-1975 HR-3975 1999	LH-1975 HR-3975 1999	LH-1975 HR-3975 1998	LH-1975 HR-3975 1998	LH-1975 HR-3975 2005	LH-1975 HR-3985 2005	LH-2010 HR-4045 2035	LH-2010 HR-4045 2035	LH-2000 HR-4025 2025	LH-2000 HR-4025 2025	LH-1975 HR-3975 2003	LH-1975 HR-3975 2003	LH-1975 HR-3975 2003	LH-1975 HR-3975 2003	LH-1975 HR-3975 1997	LH-1975 HR-3975 1997	LH-1975 HR-3975 1999	LH-1975 HR-3975 1999	LH-1975 HR-3975 1999	LH-1975 HR-3975 1999	LH-1975 HR-3975 1998	LH-1975 HR-3975 1998	LH-2080 HR-4185 2104	LH*-2080 HR-4185 2104	
3239		3998		3998		3999		3998		3995		4009		4070		4049		4005		4005		3994		3998		3997		3996		2104	4208
63558																															

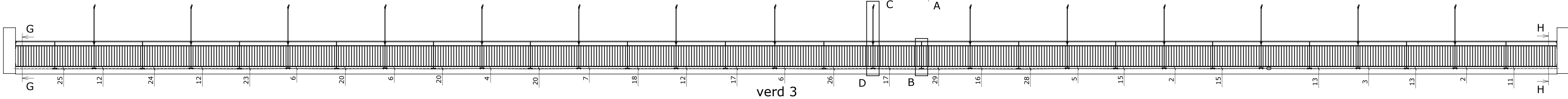

B1.3	B2.5	B1.3	B2.4	B1.2	B2.5	B1.3	B2.3	B1	B2.2	B1	B2.3	B1.1	B2.3	B1.2	B2.5	B1.4	B2.5	B1.3	B2.6	B1.4	B2.6	B1.6	B2.6	B1.5	B2.7	B1.4	B2.6	B1.6	B2.8	B1.6	
LH*-1595 HR-3215 1620	LH-1595 1620	LH-1975 HR-3975 2000	LH-1975 2000	LH-1975 HR-3975 2001	LH-1975 HR-3975 2001	LH-1975 HR-3975 1999	LH-1975 HR-3975 1999	LH-1975 HR-3975 1999	LH-1975 HR-3975 2000	LH-1975 HR-3975 2000	LH-1975 HR-3975 2001	LH-1975 HR-3975 2001	LH-2010 HR-4045 2036	LH-2010 HR-4045 2036	LH-2000 HR-4015 2022	LH-2000 HR-4015 2022	LH-1975 HR-3975 2001	LH-1975 HR-3975 2001	LH-1975 HR-3975 2000	LH-1975 HR-3975 2000	LH-1975 HR-3975 2003	LH-1975 HR-3975 2003	LH-1975 HR-3975 1999	LH-1975 HR-3975 1999	LH-1975 HR-3975 1998	LH-1975 HR-3975 1998	LH-1975 HR-3975 1999	LH-2080 HR-4185 2104	LH*-2080 HR-4185 2104		
3240		3999		4001		3998		3997		3999		4001		4072		4043		4001		3999		4005		3997		3995		3998		4208	
63553																															

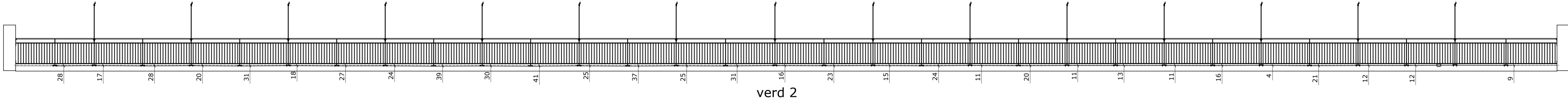

B1	B2.3	B1	B2.3	B1.2	B2.3	B1.1	B2.3	B1	B2.2	B1	B2.2	B1.1	B2.3	B1.1	B2.4	B1.2	B2.4	B1.3	B2.5	B1.5	B2.5	B1.5	B2.5	B1.4	B2.7	B1.5	B2.5	B1.5	B2.6	B1.5	
LH*-1585 HR-3195 1610	LH-1585 1610	LH-1975 HR-3975 1999	LH-1975 1999	LH-1975 HR-3975 2002	LH-1975 HR-3975 1998	LH-1975 HR-3975 1998	LH-1975 HR-3975 2003	LH-1975 HR-3985 2003	LH-1975 HR-3975 1998	LH-1975 HR-3975 1998	LH-1975 HR-3965 1997	LH-1975 HR-3965 1997	LH-2000 HR-4035 2030	LH-2000 HR-4035 2030	LH-2010 HR-4045 2033	LH-2010 HR-4045 2033	LH-1975 HR-3975 2003	LH-1975 HR-3975 2003	LH-1975 HR-3975 1998	LH-1975 HR-3975 1998	LH-1975 HR-3975 1998	LH-1975 HR-3975 1998	LH-1975 HR-3965 1998	LH-1975 HR-3965 1998	LH-1975 HR-3965 1997	LH-1975 HR-3965 2000	LH-1975 HR-3975 2000	LH-2080 HR-4200 2112	LH*-2080 HR-4200 2112		
3220		3997		4003		3996		4006		3996		3993		4060		4065		4005		3996		3996		3995		3994		4000		4223	
63545																															

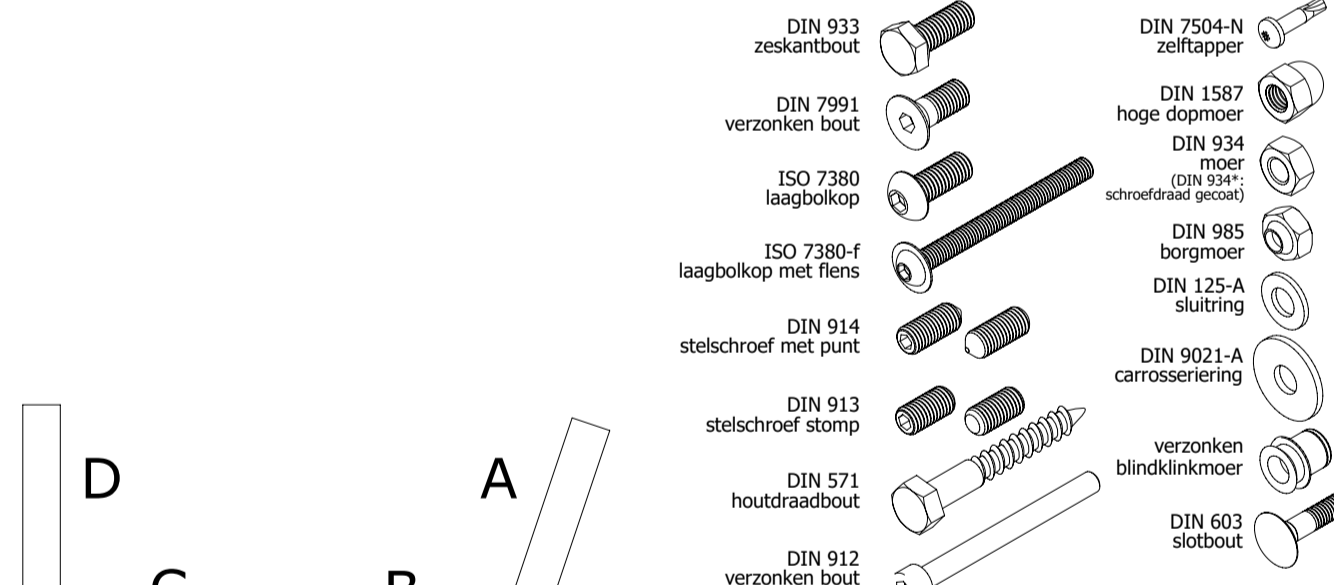
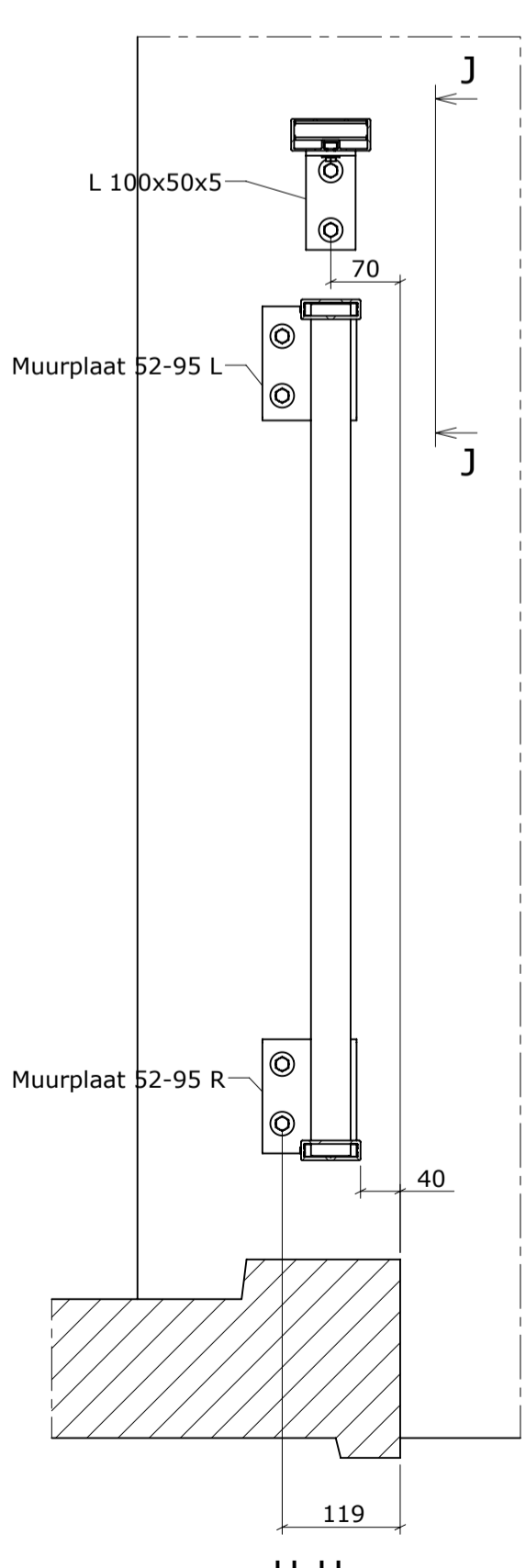
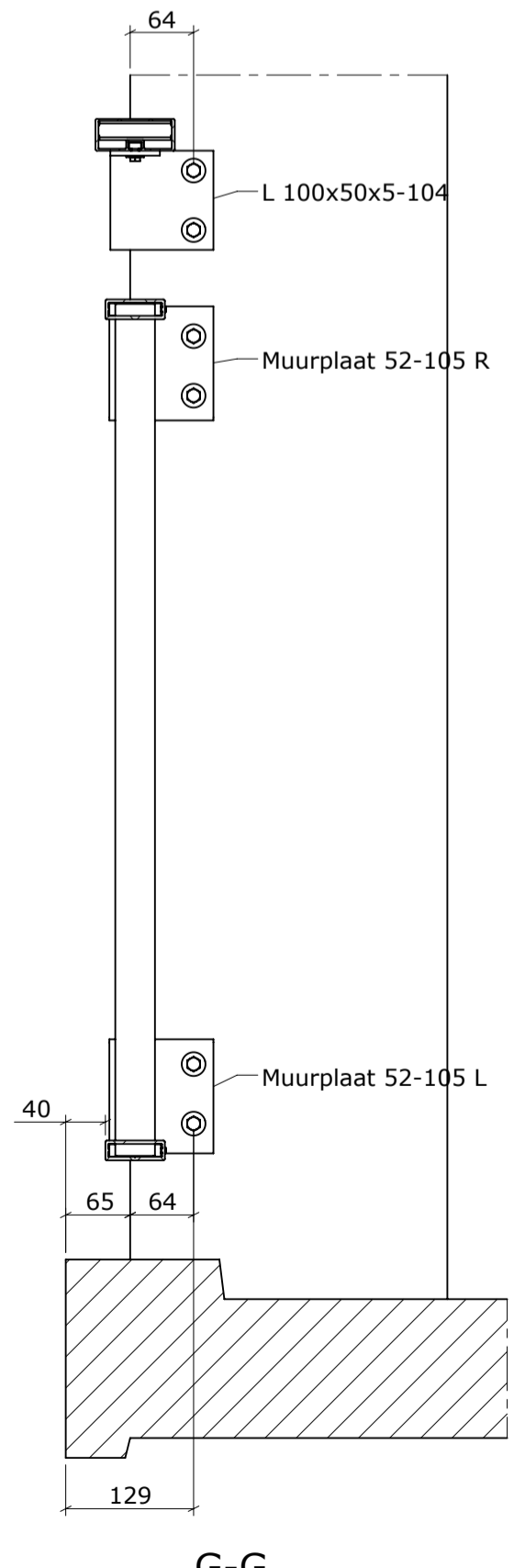
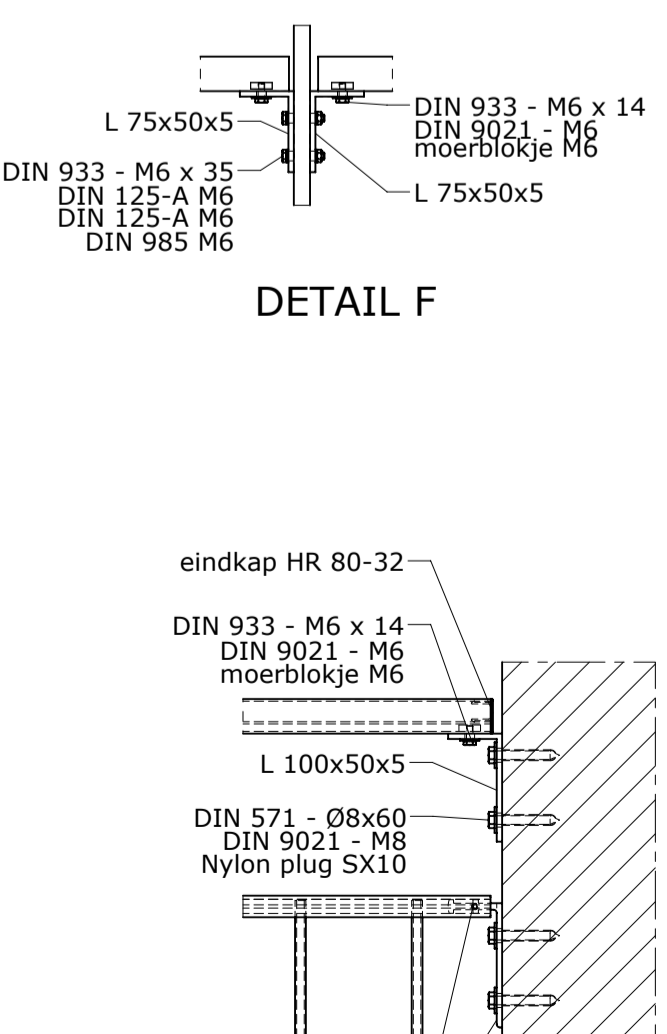
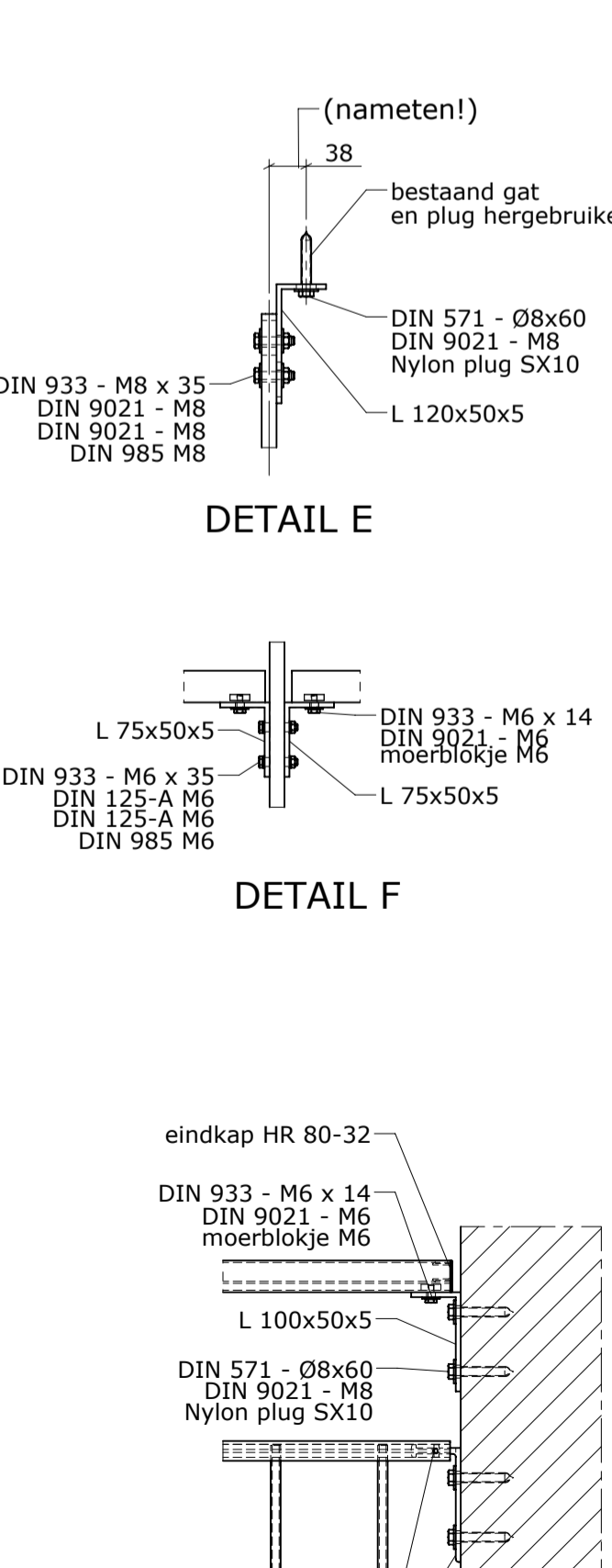
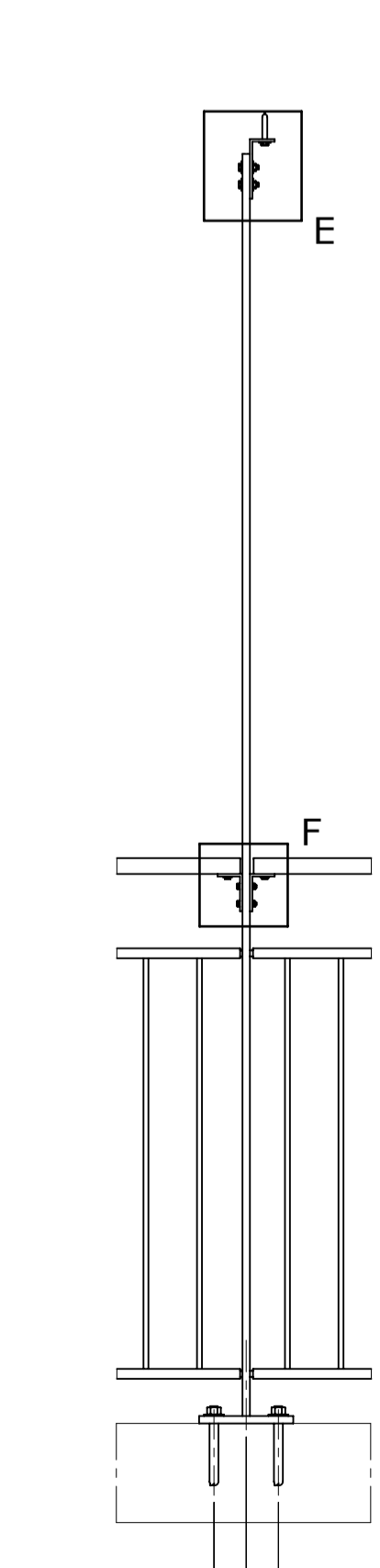
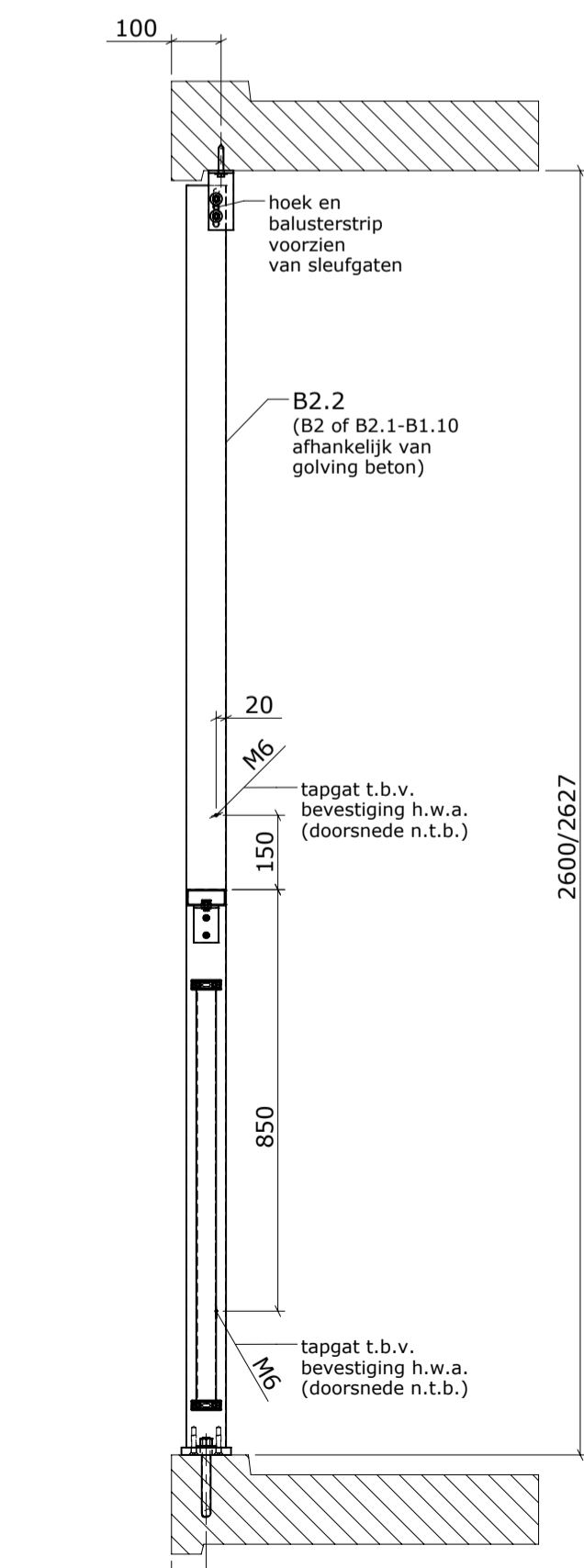
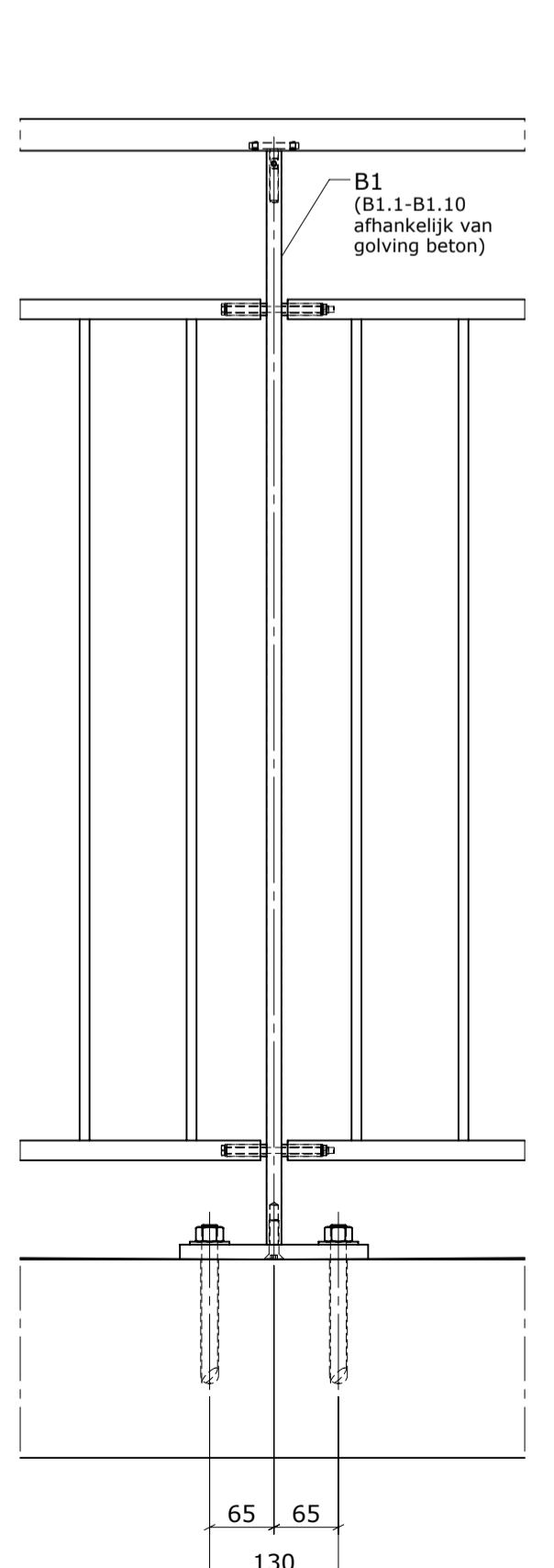
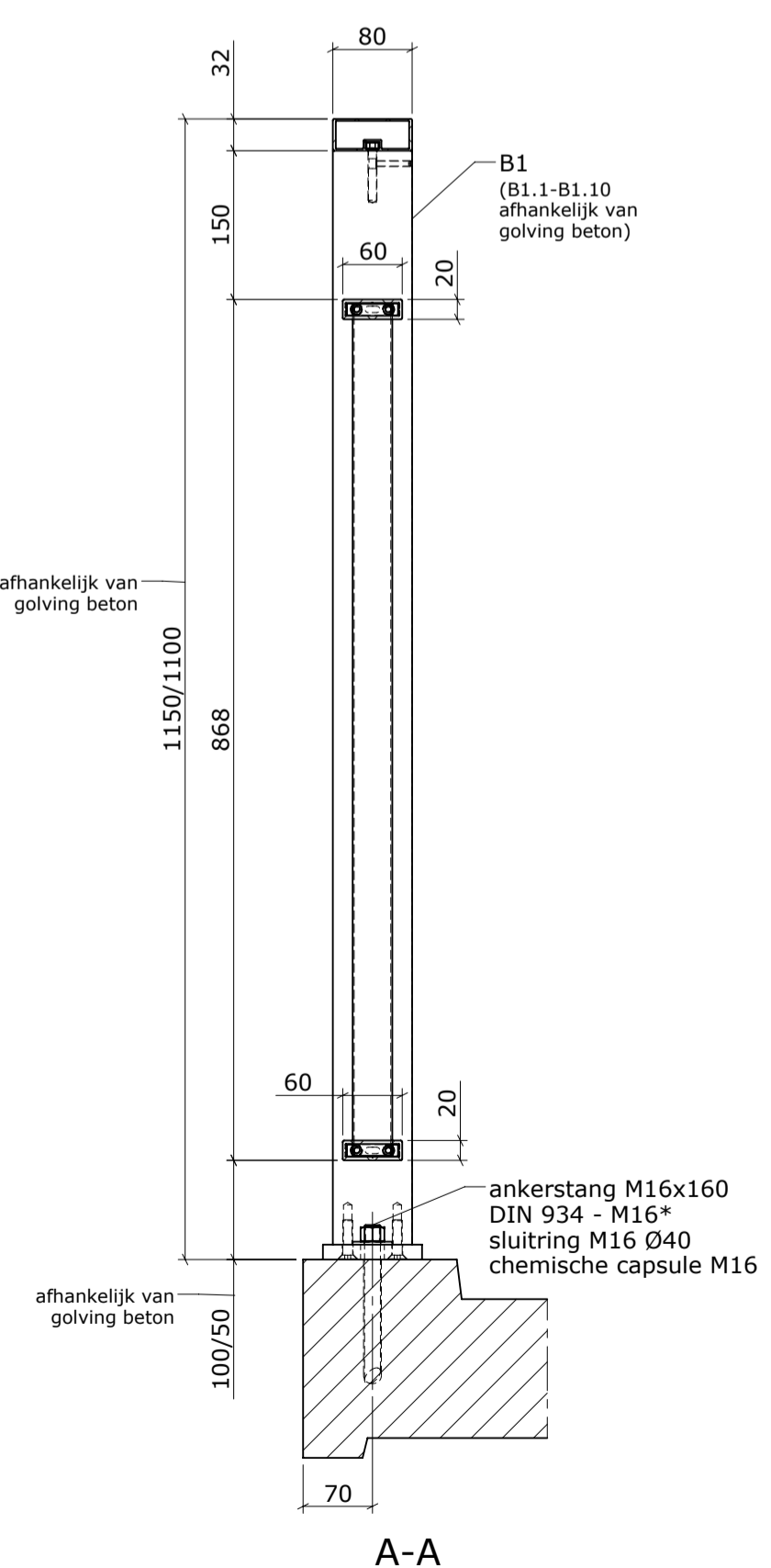
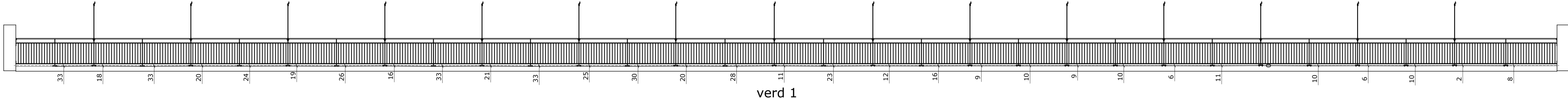

Afkortingen:
 B1 = baluster type 1
 LH = lamellenhek
 HR = handregel

Aluminium hekwerk:
 - Lamellenhek 60x20 met lamellen 40x10 (h.o.h. 108 mm)
 - montage: tussengehangen
 - stripbaluster 80x15 op beton met mechanisch bevestigde voetplaat
 - extra handregel 80x32 (bevestiging op baluster middels MBR stelpen)
 - verankering middels chemische ankersets (gaten droog geboord)
 - gevelbevestiging middels muurplaten en houtdraadboutsets
 - hekwerk horizontaal uitgelijnd t.o.v. golvend beton

Oppervlaktebehandeling: RAL 7016, 100-120 mu.
RVS-kwaliteit: A4

Wijz.:	A	B	C
Project(-fase) tek.nr. - omschr.:	Huipen Alkmaar 20.037 tek 1 - galerij Blok A		
Get.:	Datum	Naam	A1
	8-6-2020	DS	

MBR HEKWERKEN

Postbus 83, 4790 AB Klundert
 Fuutweg 1, Havennummer M460C
 Telefoon: 0168-403936
 Telefax: 0168-403823
 Website: www.mbrhekwerken.nl